



1. A charged particle is thrown in a uniform magnetic field of flux density  $1.5 \text{ Wb/m}^2$  with a speed of  $2 \times 10^7 \text{ m/sec}$  making an angle of  $30^\circ$  with the direction of field. The particle experiences a force equal to
  - (A)  $1.2 \times 10^{12} \text{ N}$
  - (B)  $2.4 \times 10^{12} \text{ N}$
  - (C)  $12 \times 10^{12} \text{ N}$
  - (D)  $24 \times 10^{12} \text{ N}$
2. The differential equation describing the oscillation of a particle is given by  $2\frac{d^2x}{dt^2} + 8\frac{dx}{dt} + 12x = 0$ . The oscillation of the particle is
  - (A) underdamped
  - (B) critically damped
  - (C) overdamped
  - (D) free SHM
3. The electric field of an electromagnetic wave is given by  $= E_0 \cos(kz - ct)\hat{x} + E_0 \sin(kz - ct)\hat{y}$ . The wave is
  - (A) elliptically polarized
  - (B) left circularly polarized
  - (C) linearly polarized
  - (D) right circularly polarized
4. A thermal neutron has a speed  $v$  at temperature  $T=300\text{K}$  and kinetic energy given by  $\frac{m_n v^2}{2} = \frac{3kT}{2}$ . Take mass of neutron as  $m_n = 1.67 \times 10^{-27} \text{ kg}$  and  $k = 1.38 \times 10^{-23} \text{ m}^2\text{kgs}^{-2}\text{K}^{-1}$ . The de-Broglie wavelength associated with this neutron is
  - (A) 32 pm
  - (B) 23.3 pm
  - (C) 14 pm
  - (D) 1.22 pm
5. In a Young's double-slit experiment using a monochromatic light of wavelength 488 nm, the separation between the slits is 0.320 mm and interference fringes are formed on the screen. How many interference fringes will be observed in the angular range of  $-30^\circ < \theta < +30^\circ$ ? Here  $\theta$  is measured from the direction of the central fringe.
  - (A) 321
  - (B) 231
  - (C) 655
  - (D) 565

---

**Space for Rough Work**

6. The radii of two soap bubbles are  $r$  and  $2r$  respectively. The excess pressures inside the bubbles are in the ratio  
 (A) 2 : 1  
 (B) 1 : 4  
 (C) 4 : 1  
 (D) 1 : 2
7. The dimension of a quantity is given by  $ML^2T^{-2}I^{-2}$ , where  $M$  is mass,  $L$  is length,  $T$  is time, and  $I$  is electric current. Which of the following quantities has this dimension ?  
 (A) Capacitor  
 (B) Inductance  
 (C) Magnetic Flux  
 (D) Electric Flux
8. In a hydrogen atom, radius of the first Bohr orbit of electron is  $5.3 \times 10^{-11}$  m. The de Broglie wavelength associated with this electron is then  
 (A)  $3.3 \times 10^{-11}$  m  
 (B)  $33 \times 10^{-11}$  m  
 (C)  $6.62 \times 10^{-13}$  m  
 (D)  $66.2 \times 10^{-13}$  m
9. The output of the logic gate is

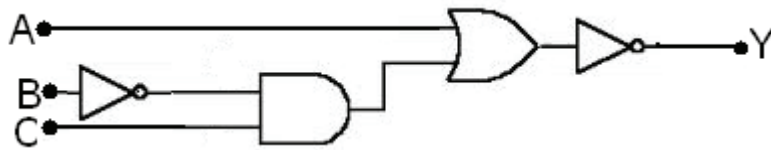

- (A)  $\bar{A} + \overline{B \cdot C}$   
 (B)  $\overline{A + B \cdot C}$   
 (C)  $A + \bar{B} \cdot C$   
 (D)  $\overline{A + \bar{B} \cdot C}$
10. What is the minimum thickness of a soap bubble needed for constructive interference in reflected light, if the light incident on the film is 750 nm ? Assume that the refractive index of the film is  $n = 4/3$ .  
 (A) 140.6 nm  
 (B) 281.2 nm  
 (C) 70.3 nm  
 (D) 210.9 nm

---

Space for Rough Work

11. Which of the following statements is not true ?
- (A) The resistance of intrinsic semiconductors decreases with increase of temperature.
- (B) Doping pure Si with trivalent impurities give p-type semiconductors.
- (C) The majority carriers in n-type semiconductors are holes.
- (D) A p-n junction can act as a semiconductor diode.
12. Two resistive networks are connected through a battery of emf 5V and internal resistance  $1\ \Omega$ , as shown below. The value of R for which the power delivered to the network by the battery will be maximum, is

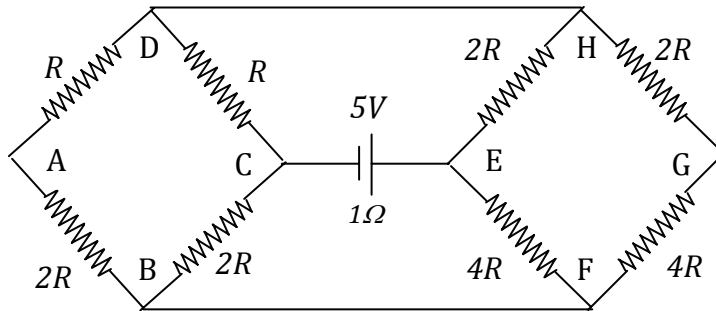

- (A)  $1\ \Omega$
- (B)  $0.5\ \Omega$
- (C)  $1.2\ \Omega$
- (D)  $2.4\ \Omega$
13. A charged particle is released from rest in a region of constant and uniform electric and magnetic fields. The two fields are parallel to each other. The path of the particle's motion will be a
- (A) straight line
- (B) circle
- (C) helix
- (D) cycloid
14. A particle of charge  $e$  and mass  $m$  is executing a circular motion with a uniform angular speed  $\omega$ . If the radius of the circular path be  $r$ , the angular momentum be  $L$  and magnetic moment due to circular loop be  $\mu$ , then
- (A) the current flowing in the circular path is proportional to the area of the loop
- (B)  $L$  is proportional to the areal velocity
- (C) the ratio of  $\mu/L$  is inversely proportional to the specific charge of the particle
- (D)  $\mu$  is proportional to  $m$

---

**Space for Rough Work**

15. A moving coil galvanometer has a resistance of  $100\ \Omega$  and shows full-scale deflection at a current of  $100\ \mu\text{A}$ . The galvanometer has to be used as an ammeter in the range of  $0\text{--}100\ \text{mA}$  so that  $100\ \text{mA}$  is the full-scale deflection current. A resistance  $R$  has to be connected in parallel. Then
- the value of  $R$  needed should be  $1.0\ \Omega$
  - when this ammeter measures  $100\ \text{mA}$ , the current flowing in galvanometer is  $40\ \mu\text{A}$
  - for higher current measurement, value of  $R$  should be larger than the present value of  $R$
  - this new ammeter cannot measure  $-100\ \text{mA}$
16. An object is moving away from a vertical concave mirror of focal length  $25\ \text{m}$ . When the distance of the object is  $100\ \text{m}$ , the velocity of the object is  $5\ \text{m/s}$  and it accelerates at  $2\ \text{m/s}^2$ . The distance of the object from the image after  $5\ \text{sec}$  is
- $300\ \text{m}$
  - $120\ \text{m}$
  - $150\ \text{m}$
  - $90\ \text{m}$
17. An electrostatic field  $\vec{E} = \hat{i} + 2\hat{j} + 3\hat{k}$  passes through the surface  $\vec{A} = 30\hat{j}$ . The electric flux coming through the surface is
- $30\ \text{unit}$
  - $90\ \text{unit}$
  - $60\ \text{unit}$
  - $120\ \text{unit}$
18. A given quantity of an ideal gas is at pressure  $P$  and absolute temperature  $T$ . The isothermal bulk modulus of the gas is
- $2P/3$
  - $P$
  - $3P/2$
  - $2P$
19. The current amplification factor of a transistor  $\alpha$  is  $0.9$ . The transistor is biased in a common-base configuration. In this connection, when the base current changes by  $4\ \text{mA}$ , the change in collector current is
- $4.44\ \text{mA}$
  - $40\ \text{mA}$
  - $36\ \text{mA}$
  - $24\ \text{mA}$

---

**Space for Rough Work**

20. A bi-convex lens of focal length 10 cm is cut along the horizontal diameter and the two halves are kept 2 mm apart symmetrically about the optical axis as shown in the figure. A monochromatic point source of light is now placed at a distance 10 cm on the optical axis. Then which of the following statements is/are correct ?

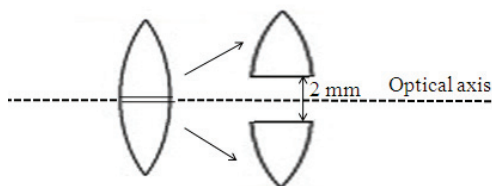

- (A) The rays emerging from each lens-half will be converging to a point on the optical axis at a distance of 5 cm from the lens-halves.
- (B) The rays emerging from each lens-half will be parallel making an angle of  $10^{-2}$  radian with the optical axis.
- (C) Rays from each lens-half will be diverging as if the source is on the optic axis at a distance of  $10/3$  cm behind the lens-halves.
- (D) The rays emerging from the upper lens-half will appear to come from a point  $10/3$  cm behind the lens-halves and 3 mm below the optical axis.
21. An infinitely long straight conductor has a circular loop of radius R meter. If a current I ampere flows through the conductor, then the magnetic induction at the centre of the circular loop is
- (A)  $\frac{\mu_0}{4\pi} \frac{2I}{R(\pi + 1)}$  Tesla
- (B)  $\frac{\mu_0}{4\pi} \frac{2I}{R}$  Tesla
- (C)  $\frac{\mu_0}{4\pi} \frac{2I}{R(\pi - 1)}$  Tesla
- (D) Zero
22. Energy liberated per fission is about 200 MeV of  ${}_{92}\text{U}^{235}$  nuclei. A fission reactor of power 1 MW consumes a mass x of  ${}_{92}\text{U}^{235}$  per day. Here x is equal to
- (A) 1 gm
- (B) 10 gm
- (C) 1 kg
- (D) 10 kg

---

**Space for Rough Work**

23. A free electron has a wave function  $\psi(x, t) = \sin(kx - \omega t)$ . Given that  $h = 6.626 \times 10^{-34}$  J-s, when  $k = 50 \text{ nm}^{-1}$ , the momentum of the electron in kg-m/s is
- (A)  $5.26 \times 10^{-22}$   
 (B)  $2.62 \times 10^{-32}$   
 (C)  $1.26 \times 10^{-12}$   
 (D)  $6.62 \times 10^{-24}$
24. A non-conducting solid sphere of radius  $R$  is uniformly charged. At a distance  $r$  from the centre of the sphere the electric field (magnitude) due to sphere
- (A)  $E \propto 1/r^2$  for  $r < R$  (inside sphere)  
 (B)  $E \propto 1/r^2$  for  $0 < r < \infty$  (everywhere except centre)  
 (C)  $E \propto 1/r^2$  for  $R < r < \infty$  (outside sphere)  
 (D)  $E = 0$  at  $r = R$  (at the surface)
25. The ground state wave function associated with a particle in a potential box of width  $L$  (i.e.,  $x = 0$  to  $x = L$ ) is given by
- (A)  $\sqrt{(2/L)} \sin [(x/L)]$   
 (B)  $\sqrt{(2/L)} \cos [(x/2L)]$   
 (C)  $\sqrt{(2/L)} \sin [2(x/L)]$   
 (D)  $\sqrt{(2/L)} \cos [2(x/L)]$
26. A circular loop of copper wire has a radius  $r$  and mass  $m$ . The loop is at rest on flat table in the horizontal plane  $xy$ . The earth's magnetic field at this point is  $\hat{i} B_x + \hat{k} B_z$ . When a current  $I$  flows through the loop, the loop starts tilting. The minimum value of current is
- (A)  $\frac{mg}{\pi r B_x}$   
 (B)  $\frac{mg}{\pi r \sqrt{B_x^2 + B_z^2}}$   
 (C)  $\frac{mg}{\pi r \sqrt{B_x B_z}}$   
 (D)  $\frac{mg}{\pi r B_z}$

---

Space for Rough Work

27. A hydrogen atom is in its  $n^{\text{th}}$  excited state. The magnetic moment due to the electron of this excited hydrogen atom is
- (A)  $\frac{neh}{2m}$   
 (B)  $\frac{me\hbar}{2n}$   
 (C)  $\frac{neh}{2\pi m}$   
 (D)  $\frac{me\hbar}{2\pi n}$
28. 5.0 kg of steam at  $200^\circ\text{C}$  is kept in a frictionless piston-cylinder based container at a pressure of 400 kPa. Heat is transferred to steam at constant pressure in a quasi-static process till the temperature reaches  $250^\circ\text{C}$ . Assume the specific volumes of steam at  $200^\circ\text{C}$  and  $250^\circ\text{C}$  as  $0.53434\text{ m}^3/\text{kg}$  and  $0.59520\text{ m}^3/\text{kg}$  respectively. The work done by the steam is then
- (A) 121.7 kJ  
 (B)  $-55.3\text{ kJ}$   
 (C) 30.4 kJ  
 (D)  $-53.5\text{ kJ}$
29. A plane diffraction grating has 100 lines per mm. The grating is illuminated by sodium light of wavelength  $5890\text{\AA}$ . The number of orders that will be visible is
- (A) 6  
 (B) 12  
 (C) 10  
 (D) 16
30. The electric fields of two electromagnetic waves in a certain region are  $E_1 = E_0 e^{ik\left(\frac{\sqrt{3}}{2}x + \frac{1}{2}y\right)}$  and  $E_2 = E_0 e^{ik\left(\frac{1}{2}x + \frac{\sqrt{3}}{2}y\right)}$  respectively. The angle between these electromagnetic fields is
- (A)  $60^\circ$   
 (B)  $30^\circ$   
 (C)  $45^\circ$   
 (D)  $120^\circ$

---

**Space for Rough Work**



31. The following reaction will yield which of the following product ?

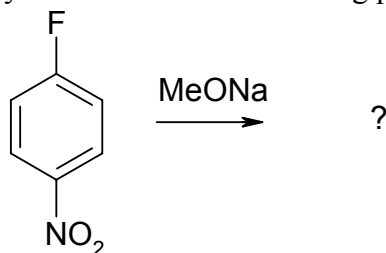

- (A) o-Nitroanisole
- (B) m-Nitroanisole
- (C) p-Nitroanisole
- (D) None of the above

32. What would be the double bond geometry in the following compound ?

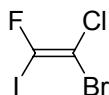

- (A) Z
- (B) E
- (C) E, Z
- (D) None of the above

33. The following diol cannot be cleaved by periodic acid mainly due to

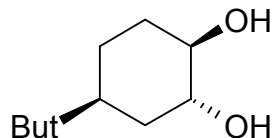

- (A) Both the OH groups are in equatorial position
- (B) Both the OH groups are in axial position
- (C) One of the OH group is in equatorial position and another is in axial position
- (D) None of the above

34. The number of gauche-butane interaction present in *cis*-1,2-dimethyl cyclohexane is

- (A) 2
- (B) 3
- (C) 4
- (D) None of the above

---

Space for Rough Work

35. What happens when a catalyst is added to a system at equilibrium ?
- (A) The heat of reaction decreases.
  - (B) The reaction follows an alternative pathway of lower activation energy.
  - (C) The potential energy of the reactants decreases.
  - (D) The potential energy of the products decreases.
36. Which of the following is false ?
- (A) Phase diagram provides information on the transformation rates.
  - (B) Phase diagram indicates the relative amounts of different phases that can be found under given equilibrium conditions.
  - (C) Phase diagram indicates the temperature at which different phases start to melt.
  - (D) Solid solubility limits are depicted by the phase diagram.
37. In a condensed system having a single-component, if the degree of freedom is zero, maximum number of co-existing phases will be
- (A) 0
  - (B) 1
  - (C) 2
  - (D) 3
38. Which of the following has maximum entropy of vapourisation ?
- (A) water (*l*)
  - (B) toluene (*l*)
  - (C) diethyl ether (*l*)
  - (D) acetone (*l*)
39. The internal energy of one mole of an ideal gas is
- (A)  $4RT$
  - (B)  $(5/2)RT$
  - (C)  $(7/2)RT$
  - (D)  $(3/2)RT$

---

**Space for Rough Work**

40. For an ideal gas the Joule-Thomson coefficient will be  
(A)  $> 0$   
(B)  $0$   
(C)  $< 0$   
(D) cannot be predicted.
41. Entropy is a measure of  
(A) randomness  
(B) orderliness  
(C) reactivity  
(D) feasibility
42. The efficiency of a Carnot engine would be unity when  
(A) the sink temperature is  $0\text{ }^{\circ}\text{C}$   
(B) the source temperature is  $1000\text{ }^{\circ}\text{C}$   
(C) the sink temperature is  $0\text{ K}$   
(D) the source temperature is  $100000\text{ K}$
43. Free energy change,  $\Delta G=0$  when  
(A) catalyst is added  
(B) the system is under equilibrium  
(C) reactants are completely consumed  
(D) reactants are initially mixed thoroughly.
44. Given the following notation for an electrochemical cell :  
 $\text{Pt(s)} \mid \text{H}_2(\text{g}) \mid \text{H}^+(\text{aq}) \parallel \text{Ag}^+(\text{aq}) \mid \text{Ag(s)}$   
Which of the following represents the overall balanced (net) cell reaction ?  
(A)  $\text{H}_2(\text{g}) + \text{Ag}^+(\text{aq}) \rightarrow 2\text{H}^+(\text{aq}) + \text{Ag(s)}$   
(B)  $\text{H}_2(\text{g}) + \text{Ag(s)} \rightarrow \text{H}^+(\text{aq}) + \text{Ag}^+(\text{aq})$   
(C)  $\text{Ag(s)} + \text{H}^+(\text{aq}) \rightarrow \text{Ag}^+(\text{aq}) + \text{H}_2(\text{g})$   
(D) None of these

---

**Space for Rough Work**

45. The structure of heteropolyacid ammonium phosphomolybdate contains
- (A) one tetrahedral and twelve octahedral units
  - (B) twelve tetrahedral and one octahedral units
  - (C) four tetrahedral and seven octahedral units
  - (D) seven tetrahedral and six octahedral units
46. The atoms in  $\text{BF}_4^-$  ion supply
- (A) 32 valence electrons
  - (B) 31 valence electrons
  - (C) 41 valence electrons
  - (D) 36 valence electrons
47. The ground state configuration of CO is
- (A)  $1\sigma^2 1\pi^2 2\pi^4 2\sigma^2$
  - (B)  $1\sigma^2 2\sigma^2 3\sigma^4 1\pi^2$
  - (C)  $1\sigma^2 2\sigma^2 1\pi^4 3\sigma^2$
  - (D)  $1\sigma^2 2\sigma^2 1\pi^2 3\sigma^4$
48. The reaction of  $\text{BCl}_3$  with excess NaCl in acidic aqueous solution gives
- (A)  $\text{BCl}_4^-$  and  $\text{Na}^+$
  - (B)  $\text{BOCl}_2$  and HCl
  - (C)  $\text{H}_3\text{BO}_3$  and NaOCl
  - (D)  $\text{H}_3\text{BO}_3$  and HCl
49. Amongst the following VO,  $\text{V}_2\text{O}_3$ ,  $\text{VO}_2$ ,  $\text{V}_2\text{O}_5$ ,  $\text{Cr}_2\text{O}_3$  and  $\text{CrO}_3$  the pair of amphoteric oxides is
- (A) VO,  $\text{Cr}_2\text{O}_3$
  - (B)  $\text{V}_2\text{O}_3$ ,  $\text{Cr}_2\text{O}_3$
  - (C)  $\text{VO}_2$ ,  $\text{Cr}_2\text{O}_3$
  - (D)  $\text{V}_2\text{O}_5$ ,  $\text{CrO}_3$

---

**Space for Rough Work**

50. The ground state electronic configuration of the  $\text{Ti}^{3+}$  is
- (A)  $[\text{Ar}]3d^2$
  - (B)  $[\text{Ar}]3d^1$
  - (C)  $[\text{Ne}]3d^9$
  - (D)  $[\text{Ar}]4s^23d^1$
51. Reaction of fluorapatite with conc.  $\text{H}_2\text{SO}_4$  gives
- (A)  $\text{P}_4$ ,  $\text{CaSiO}_3$  and  $\text{HF}$
  - (B)  $\text{H}_3\text{PO}_4$ ,  $\text{CaSO}_4$  and  $\text{CaF}_2$
  - (C)  $\text{H}_3\text{PO}_4$ ,  $\text{CaSO}_4$  and  $\text{HF}$
  - (D)  $\text{H}_4\text{P}_2\text{O}_7$ ,  $\text{CaSO}_4$  and  $\text{HF}$
52. The average N-O bond length and O-N-O angle in  $\text{NO}_2^-$  are, respectively
- (A)  $1.15 \text{ \AA}$ ,  $180^\circ$
  - (B)  $1.24 \text{ \AA}$ ,  $120^\circ$
  - (C)  $1.12 \text{ \AA}$ ,  $115^\circ$
  - (D)  $1.24 \text{ \AA}$ ,  $115^\circ$
53. Conc.  $\text{HNO}_3$  is yellow in colour due to the presence of
- (A)  $\text{NO}_2$
  - (B)  $\text{NO}$
  - (C)  $\text{N}_2\text{O}$
  - (D)  $\text{N}_2\text{O}_5$
54. At  $250^\circ\text{C}$  molten  $\text{NH}_4\text{NO}_3$  gives
- (A)  $\text{NO}$  and  $\text{H}_2\text{O}$
  - (B)  $\text{N}_2\text{O}$  and  $\text{H}_2\text{O}$
  - (C)  $\text{N}_2\text{O}$  and  $\text{H}_2\text{O}_2$
  - (D)  $\text{NO}_2$  and  $\text{H}_2\text{O}$

---

Space for Rough Work

55. Predict the absolute configuration for the following compound

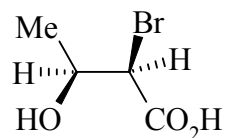

- (A) 2S, 3R
- (B) 2S, 3S
- (C) 2R, 3R
- (D) 2R, 3S

56. The following compound cannot be resolved mainly due to the fact that

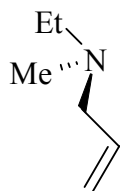

- (A) The compound is not chiral
- (B) Rapid interconversion between the enantiomers take place
- (C) The compound is liquid in nature
- (D) None of the above

57. Predict the correct order of affinity towards electrophilic substitution reaction of the following substrates :

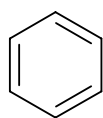

I

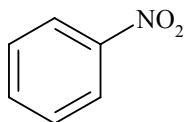

II

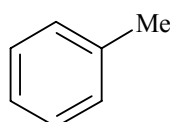

III

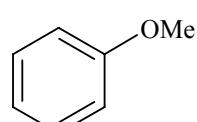

IV

- (A) IV > III > I > II
- (B) III > IV > I > II
- (C) IV > I > III > II
- (D) I > II > III > IV

---

Space for Rough Work

58. Predict the correct order of affinity towards nucleophilic substitution ( $S_N^1$ ) reaction of the following substrates :

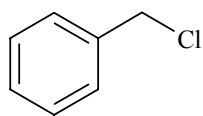

I

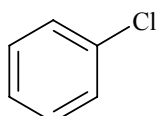

II

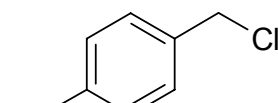

III

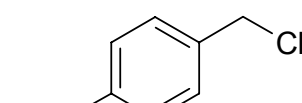

IV

- (A) II > I > IV > III  
 (B) III > IV > II > I  
 (C) IV > III > I > II  
 (D) I > III > IV > II
59. An aliphatic carbonyl compound (Mw = 86) gives a pair of oximes (with  $NH_2OH$ ) which could be reduced to an amine that is resolvable, what is the correct structure of the parent carbonyl compound ?

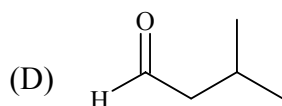
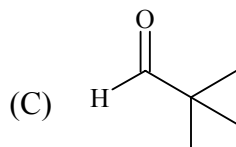
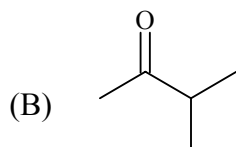
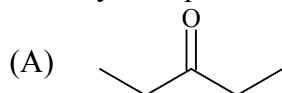

60. Reimer-Tiemann reaction of phenol involves the formation of which of the following intermediate ?
- (A) Dichlorocarbene  
 (B) Trichlorocarbene  
 (C) Trichloromethane  
 (D) Nitrene

---

Space for Rough Work

61. Match column "A" and column "B" and identify the incorrect match :

'A'-Name of the receptor	'B'-Absorbance and specific role
P <sub>r</sub>	(1) 660 nm, seed germination, flowering
P <sub>fr</sub>	(2) 735 nm, seed germination, flowering
Cryptochrome	(3) 475 nm, P <sub>r</sub> to P <sub>fr</sub> conversion, shade avoidance
Phototropin	(4) 320-400 nm, phototropic responses, or differential growth in a light gradient.

(A) P<sub>r</sub> → (1)

(B) P<sub>fr</sub> → (2)

(C) cryptochrome → (3)

(D) phototropins → (4)

62. Which of the following is an important physiological function of the plant hormone ABA ?

(A) Prohibiting precocious germination and promoting dormancy in seeds

(B) Inducing stomatal opening and desiccation

(C) Initiation of primary root and homophylly

(D) Functions as an anti-senescent hormone

63. In which of the following sequences photorespiratory processes in plants begins and ends up in the organelles ?

(A) Chloroplast → Mitochondrion → Peroxisome

(B) Chloroplast → Peroxisome → Mitochondrion

(C) Mitochondrion → Peroxisome → Chloroplast

(D) Mitochondrion → Chloroplast → Peroxisome

---

**Space for Rough Work**



64. Which of the following vector holds the largest pieces of DNA ?
- (A) Plasmids
  - (B) Bacteriophage
  - (C) YACs
  - (D) PACs
65. Which of the following statements about gene libraries is correct ?
- (A) Genes in a library can be compared to genes from other organisms by hybridization with a probe.
  - (B) Every gene in the library must be sequenced first in order to compare genes in the library to genes from other organisms.
  - (C) A gene library is only necessary to maintain known genes.
  - (D) Gene libraries can only be created for eukaryotic organisms.
66. A duplicate specimen of the holotype collected at the same time by the same person from the same population is known as
- (A) Lectotype
  - (B) Paratype
  - (C) Isotype
  - (D) Neotype
67. What is DNA coated onto when transforming plant cells with a particle gun ?
- (A) Silver
  - (B) Aluminium
  - (C) Helium
  - (D) Gold

---

**Space for Rough Work**

68. The type of pollination performed by butterflies is known as
- (A) Cantharophily
  - (B) Psychophily
  - (C) Phalaenophily
  - (D) Myrmecophily
69. Which of the following is the most popular approach for delivering gene therapy ?
- (A) Bacterial vectors
  - (B) Naked DNA
  - (C) Liposomes
  - (D) Viral vectors
70. Among the extant gymnosperms, the longest archegonial neck is found in
- (A) Cycas
  - (B) Pinus
  - (C) Ephedra
  - (D) Ginkgo
71. What can liposome do that other methods for delivering genes cannot ?
- (A) Liposomes have no other function than delivering DNA.
  - (B) Liposomes can deliver proteins to cells, such as tumour-necrosis factor.
  - (C) Liposomes can degrade extracellular DNA.
  - (D) Liposomes can only deliver DNA to specific cells.
72. Palea is a part of following inflorescence :
- (A) Spadix
  - (B) Spike
  - (C) Spikelet
  - (D) Capitulum

---

**Space for Rough Work**

73. Which of the following combinations is not correct ?

Column 'A' (Diagnostic feature)	Column 'B' (Family)
(a) Pollinia	(i) Poaceae
(b) gynobasic style	(ii) Lamiaceae
(c) obliquely placed ovary	(iii) Solanaceae
(d) cruciform corolla	(iv) Brassicaceae

- (A) (a) – (i)
- (B) (b) – (ii)
- (C) (c) – (iii)
- (D) (d) – (iv)

74. Morphologically distinct form within a species produced by natural selection is known as

- (A) Ecotype
- (B) Ecocline
- (C) Ecad
- (D) Ecotone

75. Anneau initial is associated with

- (A) Root apical meristem of angiosperms
- (B) Shoot apical meristem of angiosperms
- (C) Shoot apical meristems of gymnosperms
- (D) Shoot apical meristem of pteridophytes

76. For successful completion of which of the following type of genetic recombinations found in bacteria 'competence factor' is required ?

- (A) Conjugation
- (B) Transduction
- (C) Transformation
- (D) Binary fission

---

**Space for Rough Work**

77. A normal chromosome has the following gene sequence :

A B C D ○ E F G H . Determine the chromosomal aberration /mutation illustrated by the following chromosomes :

(a) A B C F E ○ D G H and (b) A D ○ E F B C G H

- (A) Paracentric inversion and tandem duplication respectively.
- (B) Duplication and reciprocal translocation respectively.
- (C) Reciprocal translocation and paracentric inversion respectively.
- (D) Pericentric inversion and non-reciprocal translocation respectively.

78. Glycosylase is a repair enzyme of DNA damage. In which of the following types of DNA repair is it involved ?

- (A) Nucleotide excision repair
- (B) Base excision repair
- (C) UV-induced pyrimidine dimers
- (D) Methyl-directed mismatch repair

79. During translation, peptide bond formation is catalyzed by

- (A) EF-G
- (B) Aminoacyl-tRNA synthetase
- (C) Peptidyl tranferase
- (D) Transformylase

80. Telomerase is a type of

- (A) Reverse transcriptase enzyme
- (B) Ligase enzyme
- (C) DNA polymerase enzyme
- (D) RNA dependent RNA polymerase enzyme

---

**Space for Rough Work**

81. Which of the following is an example of “repetitive DNA” as well as “Transposon” in Eukaryotes ?
- (A) Tn 3.
  - (B) Ac-Ds.
  - (C) P elements.
  - (D) LINES.
82. Suppose chromosome number of endosperm cells in *Arabidopsis thaliana* is 15. What will be the chromosome number in a cell of this plant which has undergone nullisomic mutation ?
- (A) 8
  - (B) 13
  - (C) 12
  - (D) 17
83. Which of the following statements regarding extra-chromosomal eukaryotic genomes is incorrect ?
- (A) The DNA molecules residing in mitochondria and chloroplasts are devoid of histones.
  - (B) These genomes are circular and comparable to viral genome regarding size.
  - (C) Chloroplast genome encodes both subunits of rubisco.
  - (D) Most polypeptides encoded by mitochondrial or chloroplast genomes are components of multimeric proteins that also contain subunits encoded by the nuclear genome.

---

**Space for Rough Work**

84. Which of the following is correct matching of an organelles and its respective function ?

<b>P(Organelles)</b>	<b>Q(Function)</b>
(a) Peroxisome	(i) Generate fat from carbohydrates in fat storing seeds.
(b) Smooth endoplasmic reticulum	(ii) Synthesis of cholesterol and lipids.
(c) Golgi complex	(iii) Initiation of glycosylation of protein.
(d) Mitochondria	(iv) Reduction of fat molecules.

- (A) (a) – (i)
- (B) (b) – (ii)
- (C) (c) – (iii)
- (D) (d) – (iv)

85. Which statement about enzyme inhibition is not true ?

- (A) A competitive inhibitor binds the active site of the enzyme.
- (B) An allosteric inhibitor binds a site on the active form of the enzyme.
- (C) Noncompetitive inhibition cannot be completely overcome by the addition of more substrate.
- (D) Competitive inhibition can be completely overcome by the addition of more substrate.

86. Most plant cells display a cyanide-resistant respiration. The enzyme responsible for this cyanide resistant respiration is

- (A) Rotenone-insensitive dehydrogenase
- (B) UC P-1
- (C) SHAM
- (D) Ubiquinol oxidase or alternative oxidase.

---

**Space for Rough Work**

87. In plants fatty acids are synthesized exclusively in the
- (A) Cytosol
  - (B) Mitochondria
  - (C) Plastids
  - (D) ER
88. Plant roots actively absorb nitrate from the soil and assimilate most of this nitrate initially into nitrite in the cytosol involving transfer of 2 electrons. The Molybdenum dependent enzyme that catalyzes this reaction is
- (A) Nitrogenase
  - (B) GOGAT
  - (C) Nitrite reductase
  - (D) Nitrate reductase
89. Choose the correct sequence of taxonomic ranks of land plants in descending order :
- (A) Tribe – Section – Genus – Species – Variety
  - (B) Tribe – Genus – Section – Species – Variety
  - (C) Variety – Section – Tribe – Genus – Species
  - (D) Variety – Tribe – Section – Genus - Species
90. The complete oxidation of sucrose molecule by aerobic respiration yields about
- (A) 38 molecules of ATP.
  - (B) 52 molecules of ATP.
  - (C) 60 molecules of ATP.
  - (D) 48 molecules of ATP.

---

**Space for Rough Work**

91. Which one of the following is NOT correct for birds ?
- (A) Presence of diaphragm
  - (B) Presence of Sinus venous
  - (C) Homiothermy
  - (D) Presence of four-chambered heart
92. In which one of the following groups notochord is only present during embryonic development ?
- (A) Cephalochordata
  - (B) Hemichordata
  - (C) Agnatha
  - (D) Gnathostomata
93. When chromosome condensation and microtubules formation begins in the meiosis ?
- (A) G1 phase
  - (B) S phase
  - (C) G2 phase
  - (D) Prophase
94. Foramen of Panizza is found in the heart of
- (A) Phrynosoma
  - (B) Crocodile
  - (C) Sphenodon
  - (D) Birds

---

**Space for Rough Work**



95. The heart of teleosts is similar to that of cartilaginous fishes, except
- (A) A bulbus arteriosus is present.
  - (B) A conus arteriosus is present.
  - (C) A spiral valve is present in conus arteriosus.
  - (D) Ventral aorta is short.
96. The protein present in the arms of microtubules is
- (A) Nexin
  - (B) Dynein
  - (C) Desmin
  - (D) Vimentin
97. Maturation of sperms occurs in
- (A) Seminiferous tubules
  - (B) Vas deferens
  - (C) Seminal vesicles
  - (D) Epididymis
98. Male *Ascaris* can be distinguished from female by the presence of
- (A) Oral suckers
  - (B) Lips
  - (C) Curved Posterior end with a pair of pineal setae
  - (D) Blunt posterior end

---

**Space for Rough Work**

99. Fangs of snakes are modified
- (A) Canines
  - (B) Maxillary teeth
  - (C) Incisors
  - (D) None of the above
100. What is correct for test tube babies ?
- (A) Fertilization is external and foetus formation is internal
  - (B) Fertilization is internal and foetus formation is external
  - (C) Fertilization and foetus formation are external
  - (D) Fertilization and foetus formation are internal
101. In which of the following do four pulmonary veins open by a common aperture in the left auricle ?
- (A) Frogs
  - (B) Lizards
  - (C) Pigeons
  - (D) All of these
102. Which one of the following statements is NOT correct ?
- (A) A malignant tumor is cancer.
  - (B) Cyst and polyps are malignant tumors.
  - (C) Benign tumor is not cancer.
  - (D) Cancer is a genetic disease but it is rarely inherited.
103. Among Echinoderms, light producing cells are found only in
- (A) Asterozooids
  - (B) Holothurozooids
  - (C) Echinozooids
  - (D) Ophiurozooids

---

**Space for Rough Work**

104. Coelom is formed by the

- (A) Ectoderm
- (B) Endoderm
- (C) Mesoderm
- (D) Both ectoderm and mesoderm

105. Red coral is

- (A) *Alcyonium*
- (B) *Tubipora*
- (C) *Meandrina*
- (D) *Corallium*

106. Infective stage of a liver fluke is the

- (A) Miracidium
- (B) Cercaria
- (C) Metacercaria
- (D) Redia

107. In the life cycle of plasmodium, all stages are haploid except

- (A) Oocyst
- (B) Schizont
- (C) Merozoite
- (D) Sporozoite

---

Space for Rough Work

108. The correct sequence of developmental stages of *Ascaris* in human is
- (A) Outside – stomach – liver spleen – lung – intestine – outside
  - (B) Outside – trachea – lung – liver – intestine – outside
  - (C) Outside – trachea– lung – heart – liver– intestine – outside
  - (D) Outside – intestine – liver – heart – lung – intestine – outside
109. *Taeniasolium* passes to the secondary host at the stage of
- (A) Cysticerus
  - (B) Hexacanth
  - (C) Bladder worm
  - (D) Mracidium
110. During the course of origin of life
- (A) RNA was first evolved and from RNA, DNA was evolved by reverse transcription.
  - (B) DNA was first evolved.
  - (C) DNA was first evolved and from DNA, RNA was evolved possibly by transcription.
  - (D) Both DNA and RNA evolved at the same time.
111. Which one of the following enzymes destroys  $H_2O_2$  ?
- (A) D–aminooxidase
  - (B) Urate oxidase
  - (C) Catalase
  - (D)  $\alpha$ –hydroxylic acid oxidase
112. The process in which cells play an active role in their own death is known as
- (A) Apolysis
  - (B) Autolysis
  - (C) Necrosis
  - (D) Apoptosis

---

**Space for Rough Work**

113. For birds, what replaces the action of teeth in grinding up food ?
- (A) Hard bony ridges in the beak
  - (B) Pebble in the gizzard
  - (C) An extremely muscular esophagus
  - (D) The normal bird diet does not require grinding for digestion.
114. A man has increased BMR, heartbeat, blood pressure and bulged eyes. These symptoms are of
- (A) Gull's disease
  - (B) Addison's disease
  - (C) Cushing's syndrome
  - (D) Grave's disease
115. Mitochondria are absent in human
- (A) Liver cells
  - (B) Brain cells
  - (C) Erythrocytes
  - (D) Osteoblasts
116. Which one of the following is not in eukaryotes ?
- (A) Lysosome
  - (B) Ribosome
  - (C) Peroxisome
  - (D) Mesosome

---

**Space for Rough Work**

117. Which one of the following is responsible for speciation ?

- (A) Natural selection
- (B) Mutation
- (C) Reproductive isolation
- (D) Random mating

118. The connecting link between Echinoderms and chordates is

- (A) Oikopleura
- (B) Archaeopteryx
- (C) Balanoglossus
- (D) Antedon

119. Anadromous fish migrates from

- (A) Estuary to river
- (B) Sea to river
- (C) River to sea
- (D) Sea to river

120. Islets of Langerhans secrete

- (A) Insulin, secretion and renin
- (B) Insulin, glucagon and renin
- (C) Insulin and glucagon
- (D) Insulin, glucagon and epinephrine

---

Space for Rough Work

**Space For Rough Work**